

Electronic Super Knips

- > Precision pliers for ultra fine cutting work, e. g. in electronics and fine mechanics
- > Ground, very sharp cutting edges without bevel
- > Precision shaped tips cut wires flush to a surface from $\varnothing 0.2$ mm.
- > Shear cut with controlled micro cutting edge misalignment for the most precise cutting of even the thinnest of wires and for a long service life
- > Joint with stainless steel rivet
- > Extremely smooth movement for minimum operator fatigue
- > With opening spring and opening limiter
- > Electrically discharging handles - dissipative
- > DIN ISO 9654

78 03 125/ESD / 78 23 125

- > INOX tool steel; cutting edge hardness approx. 54 HRC

78 13 125/ESD

- > INOX tool steel; cutting edge hardness approx. 54 HRC; with lead catcher – no uncontrolled loss of cut wire ends

78 31 125

- > Cutting edges additionally induction-hardened, cutting edge hardness approx. 60 HRC; with narrow head; special tool steel, burnished

78 41 125

- > With lead catcher - no uncontrolled loss of cut wire ends; with narrow head; cutting edges additionally induction-hardened, cutting edge hardness approx. 60 HRC; special tool steel, burnished

78 61 125/ESD

- > Also suitable for cutting glass fibre cables (fibre optics); cutting edges additionally induction-hardened, cutting edge hardness approx. 64 HRC; Special tool steel, oil hardened in multiple stages

78 71 125/ESD

- > With lead catcher – no uncontrolled loss of cut wire ends; cutting edges additionally induction-hardened, cutting edge hardness approx. 64 HRC; special tool steel, burnished



78 03 125



78 03 125 ESD



78 06 125



78 13 125



78 23 125



78 31 125



78 41 125

Models also for hard wire

78 81 125

- > Precision-ground cutting edges with very small bevel suitable also for hard wire; cutting edges additionally induction-hardened, cutting edge hardness approx. 64 HRC; special tool steel, burnished

78 91 125

- > Precision-ground cutting edges with very small bevel suitable also for hard wire; with lead catcher – no uncontrolled loss of cut wire ends; cutting edges additionally induction-hardened, cutting edge hardness approx. 64 HRC; special tool steel, burnished

ESD pliers (electrostatic discharge)

Electrostatic energy is discharged through the handles in a gradual and controlled manner. Which protects components endangered by electrostatic discharge. In accordance with applicable standards, e.g. IEC TR 61 340-5, DIN EN 61 340-5, SP Method 2472



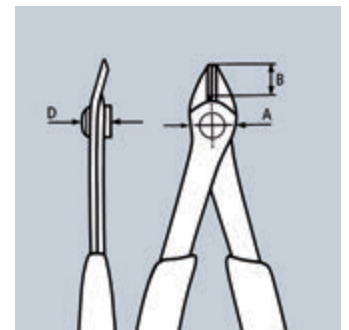
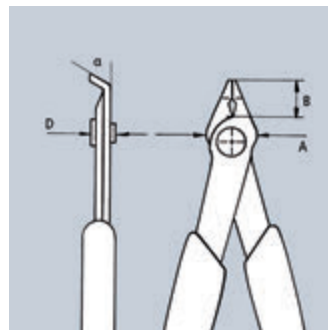
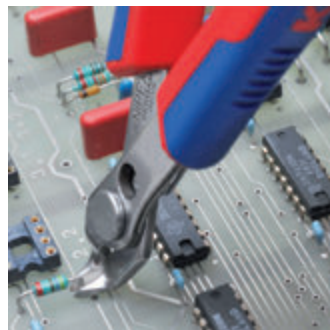
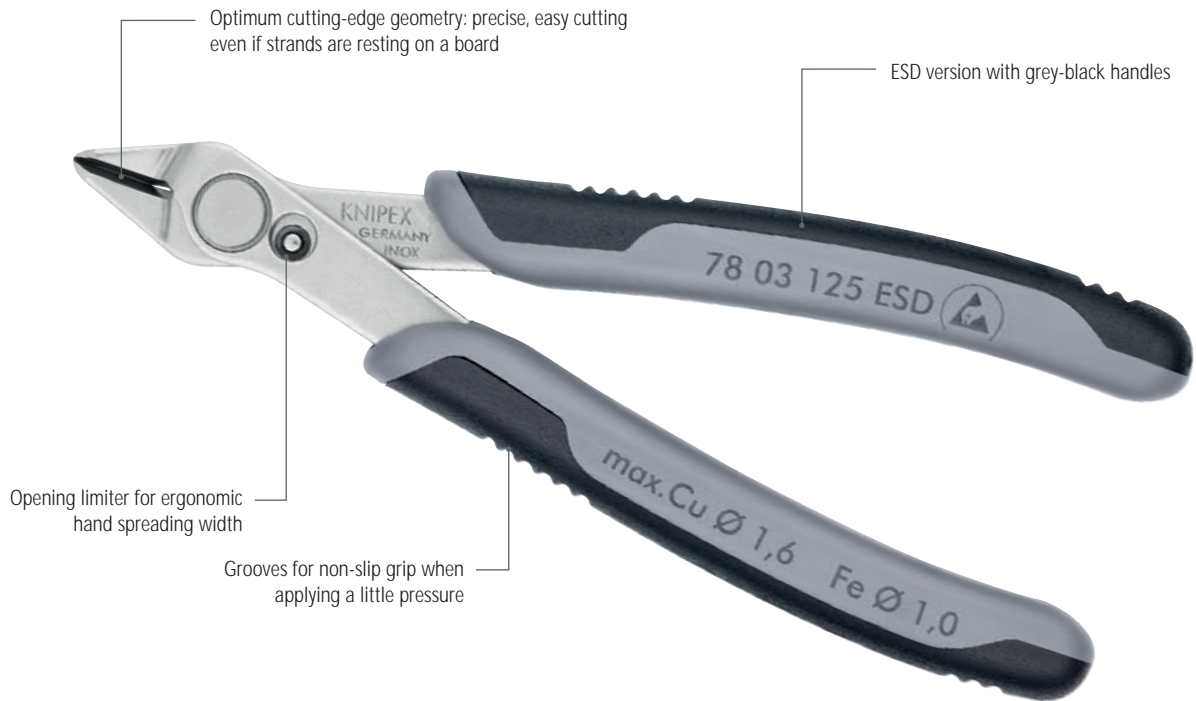

Article No.	EAN	↔ mm	Icons	Pliers	Head	Handles	Cutting capacities			Dimensions			
							Ø mm	Ø mm	Ø mm	B mm	A mm	D mm	g
78 03 125	035381	125	MM		polished	with multi-component grips	1.6	1.0		9.0	13.5	7.5	56
78 03 125 ESD	025146	125	MM		polished	with multi-component grips	1.6	1.0		9.0	13.5	7.5	55
78 06 125	084099	125	MM		polished	insulated with multi-component grips, VDE-tested	1.6	1.0		9.0	13.5	7.5	60
78 13 125	035398	125	MM		polished	with multi-component grips	1.6	1.0		9.0	13.5	7.5	57
78 13 125 ESD	025153	125	MM		polished	with multi-component grips	1.6	1.0		9.0	13.5	7.5	57
78 23 125	043096	125	MM		polished	with multi-component grips	1.0	0.6		5.5	13.5	7.5	55
78 31 125	039778	125	MM	burnished	burnished	with multi-component grips	1.0			9.0	12.5	7.5	55
78 41 125	040767	125	MM	burnished	burnished	with multi-component grips	1.0			9.0	12.5	7.5	57
78 61 125	035404	125	MM	burnished	burnished	with multi-component grips	1.6	1.2		9.0	13.5	7.5	56
78 61 125 ESD	025184	125	MM	burnished	burnished	with multi-component grips	1.6	1.2		9.0	13.5	7.5	56
78 71 125	043799	125	MM	burnished	burnished	with multi-component grips	1.6	1.2		9.0	13.5	7.5	57
78 71 125 ESD	025191	125	MM	burnished	burnished	with multi-component grips	1.6	1.2		9.0	13.5	7.5	57
78 81 125	065074	125	MM	burnished	burnished	with multi-component grips	1.6	1.2	0.6	9.0	13.5	7.5	57
78 91 125	065081	125	MM	burnished	burnished	with multi-component grips	1.6	1.2	0.6	9.0	13.5	7.5	57